

REV	DESCRIPTION OF REVISION	E.C.N.	BY	APPROVED	DATE
A	CLASS STOP WAS .043 REF. EYELET REV. B ON 10-07-10		E.C.	E.T.W.	3-06-15

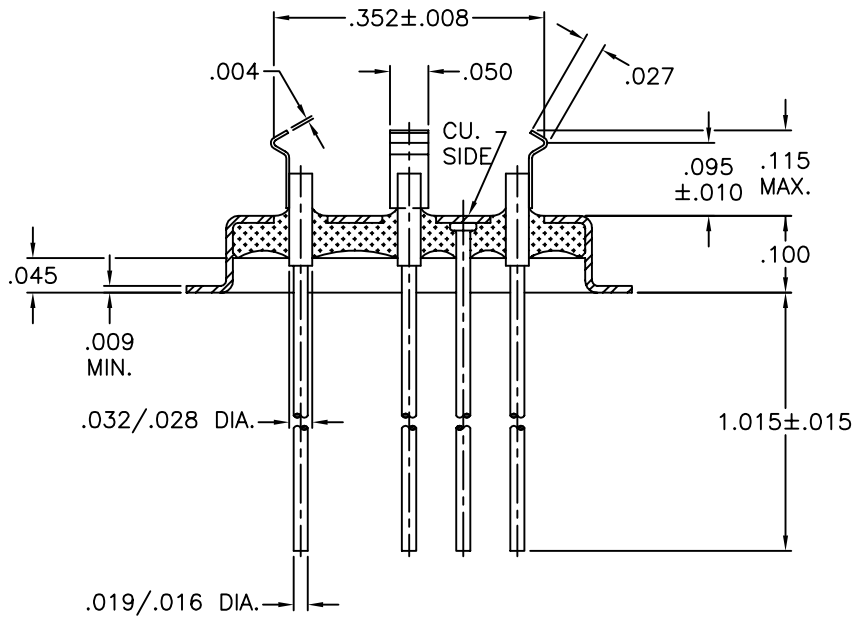
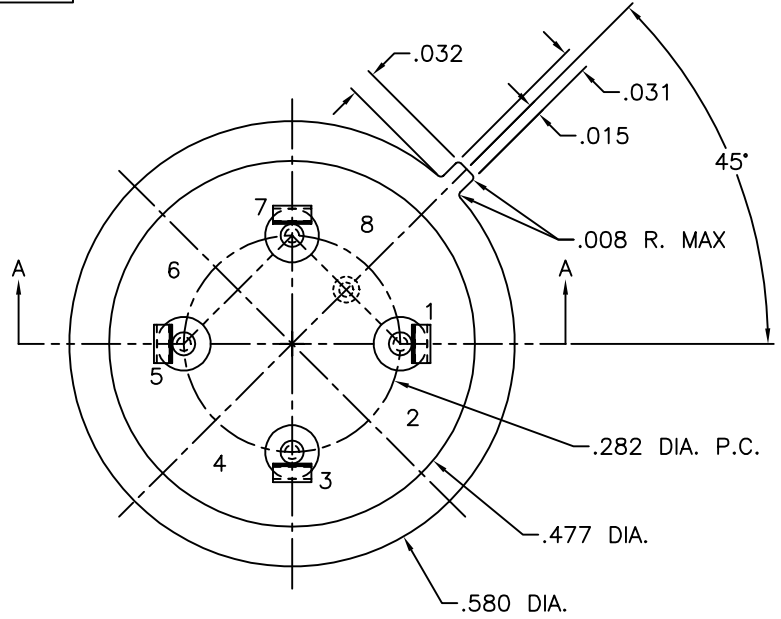

SECTION A-A

**MATERIAL:**

EYELET - 30/70 COPPER CLAD KOVAR.  
GLASS - 7052 OR EQUAL, OPAQUE.  
LEADS - ASTM F-15 ALLOY, KOVAR.  
MOUNT - 205 NICKEL, FULL HARD.

**PLATING:**

1. OPTION: RoHS COMPLIANT ELECTROLESS NICKEL PLATE OF 100 MICROINCHES MINIMUM FINAL PLATE.
2. OPTION: RoHS COMPLIANT ELECTROLESS NICKEL PLATE OF 100 MICROINCHES MINIMUM FOLLOWED BY A RoHS COMPLIANT LEAD FREE SOLDER COAT, ON LEADS ONLY.
3. OPTION: RoHS COMPLIANT ELECTROLESS NICKEL PLATE OF 100 MICROINCHES MINIMUM FOLLOWED BY A GOLD FLASH OF .99999 PURE 24 KART GOLD UP TO A MAX. OF 8 MICROINCHES.

DRAWN BY: E.T.W. 06-11-10	MATERIAL: SEE ABOVE			TOLERANCING PER ANSI Y14.5 .X ± .005 .XXX ± .005 .XX ± .005 ANG ± 5° UNLESS OTHERWISE SPECIFIED		 Legacy Technologies Inc. 6700 W. 47th TERR. MISSION, KS. 66203 TEL: 913-432-2487 FAX: 913-432-0570
	CHECKED BY: E.T.W. 06-11-10	APP. SPECS	SUPERSEDES	NEXT ASSY	SCALE: 4:1	
APPROVED BY:	TITLE: HC-37/U (COLD WELD TO-8) W/ V-CLIPS				PART NUMBER: CW-T08-BW-D-VN450A RoHS	A
					FILE: HC00091A	PAGE 1 of 1